



SHF Communication Technologies AG

Wilhelm-von-Siemens-Str. 23D • 12277 Berlin • Germany

Phone +49 30 772 051-0 • Fax +49 30 753 10 78

E-Mail: sales@shf-communication.com • Web: www.shf-communication.com

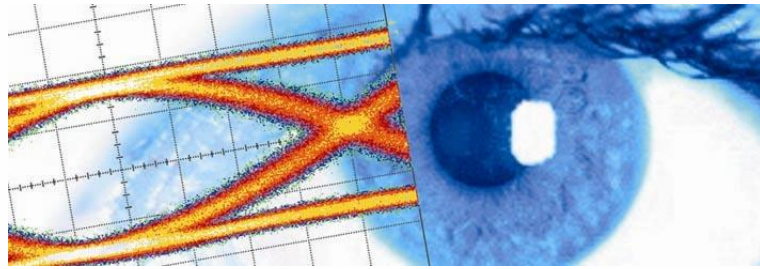

Datasheet

SHF S126 A

Broadband Amplifier





Description

The SHF S126 A broadband amplifier is the RoHS compliant successor of the popular SHF 826H. By applying new packaging techniques, this amplifier keeps the RF parameters, such as bandwidth and output power, at the same high level as the predecessor while enhancing the gain and the signal quality.

Data rates up to 32 Gbps with output amplitudes of up to 12 V are possible.

The S126 A is a two-stage amplifier design, using proprietary monolithic microwave integrated circuits (MMICs) inside. An internal voltage regulation protects the amplifier against accidental reverse voltage connection and makes it robust against line voltage ripple.

Ease of Use

Upon delivery, the amplifier is already pre-set to deliver maximum gain, maximum output amplitude and nominally 50% crossing.

These settings can be modified in an easy to use graphical user interface, as shown below. For connecting the amplifier to the computer, the USB to I2C converter cable, as well as the required software are included with each amplifier with no extra charge.

Once new settings are stored on the device the amplifier will remember the settings until further changes are made. There is no need to connect a computer to the device unless gain, maximum amplitude or crossing adjustments are to be made.

The software is available for download at www.shf-communication.com .

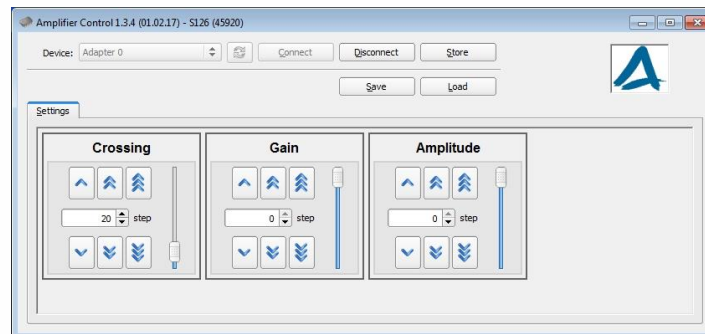

GUI of the SHF amplifier control software

Available Options

- 01: DC return on input (max. ± 1.75 V, max. 35 mA)¹
- 02: Built-in bias tee on input (max. ± 9 V, max. 220 mA)¹
- 03: DC return on output (max. ± 1.75 V, max. 35 mA)¹
- 04: Built-in bias tee on output (max. ± 9 V, max. 220 mA)¹
- MP: Matches the phase of two amplifiers

¹ The options 01 & 02 or 03 & 04 cannot be combined.

If an option is chosen, the maximum gain and the maximum output power might be reduced by up to 1 dB. The low frequency 3 dB Point might be increased up to 100 kHz. The DC resistance of a bias tee is about 3 Ω .



Specifications – SHF S126 A

Parameter	Unit	Symbol	Min	Typ	Max	Conditions
Absolute Maximum Ratings						
Maximum RF Input Power in Operation	dBm V	$P_{in\ max}$			4 1	peak to peak voltage
Maximum RF Input Power without Power Supply	dBm V	$P_{in\ max}$			10 2	peak to peak voltage
DC Voltage at RF Input	V				±9	
DC Voltage at RF Output	V				±9	
Supply Voltage	V		11		13	0.6 A, reverse voltage protected
Case Temperature ²	T_{case}	°C	10	45	50	
Electrical Characteristics (At 45°C case temperature, unless otherwise specified)						
High Frequency 3 dB Point	GHz	f_{HIGH}	25			
Low Frequency 3 dB Point	kHz	f_{LOW}			80	
Gain	dB	S_{21}	28	29		non-inverting measured at $P_{in}=-27$ dBm
Max. Gain Reduction	dB		-2.5	-3	-4	Control via software interface
Output Power at 1 dB Compression	dBm V	P_{01dB}	23 8.9			50 MHz...15 GHz peak to peak voltage
Output Power at 2 dB Compression	dBm V	P_{02dB}	24 10			50 MHz...15GHz peak to peak voltage
Output Power at 3 dB Compression	dBm V	P_{03dB}	25 11.2			50 MHz...15 GHz peak to peak voltage
Crossing Control Range	%		0		10	Control via software interface @ 450 mV input signal amplitude
Input Reflection	dB	S_{11}			-8	< 25 GHz
Output Reflection	dB	S_{22}			-10 -5	< 13 GHz < 20 GHz

² If operated with heat sink (part of the delivery) at room temperature there is no need for additional cooling.



Parameter	Unit	Symbol	Min	Typ	Max	Conditions
Rise Time/Fall Time	ps	t_r/t_f			13 17	20%...80%, 11 V ≤ Vout ≤ 12 V Deconvoluted ^{3,4} Full Setup ³
Jitter	fs	J_{RMS}		700 750	850 900	Vout ~12 V, 32 Gbps Deconvoluted ^{3,4} Full Setup ³
Group Delay Ripple	ps				±50	1 GHz...15 GHz, 160 MHz aperture
Power Consumption	W			6.2		12 V supply voltage
Mechanical Characteristics						
Input Connector						2.92 mm (K) female ⁵
Output Connector						2.92 mm (K) male ⁵

Output Amplitude Adjustment

The Output Amplitude can be adjusted by the GUI. The maximum possible reduction depends on the output amplitude itself, i.e. a minimum input power of -3 dBm is required to achieve a output power reduction of at least 4 dB. Lower output power levels will result in an reduced output power reduction range. By using the Amplitude Adjustment it is required to adjust the crossing too.

³ Measured with the following setup: SHF 12103A BPG -> DUT (SHF S126 A) -> Agilent 86100A with 70 GHz sampling head and precision time base.

⁴ Calculation based on typical results of setup without DUT :

$$t_r/t_f \text{ deconvoluted} = \sqrt{(t_r/t_f \text{ full setup})^2 - (t_r/t_f \text{ setup w/o DUT})^2} = \sqrt{(t_r/t_f \text{ full setup})^2 - 11 \text{ ps}^2}$$

$$J_{RMS} \text{ deconvoluted} = \sqrt{(J_{RMS} \text{ full setup})^2 - (J_{RMS} \text{ setup w/o DUT})^2} = \sqrt{(J_{RMS} \text{ full setup})^2 - 300 \text{ fs}^2}$$

⁵ Other gender configurations are available on request.

Other connector types, e.g. 1.85mm (V) or Mini-SMP (GPPO®) connectors, are also available but may impact the bandwidth and reflection characteristic.



Typical S-Parameters, Group Delay and Phase Response

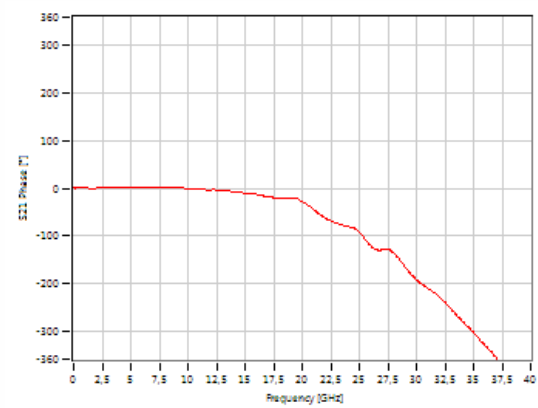
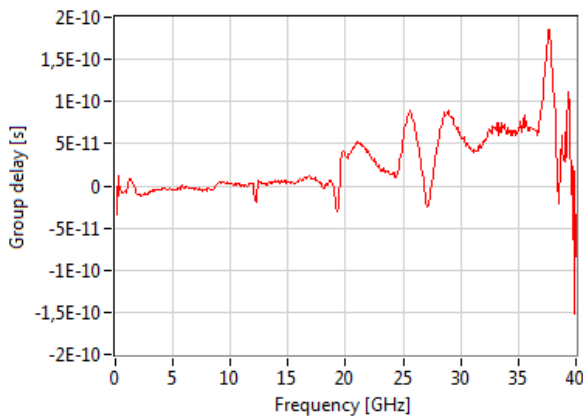
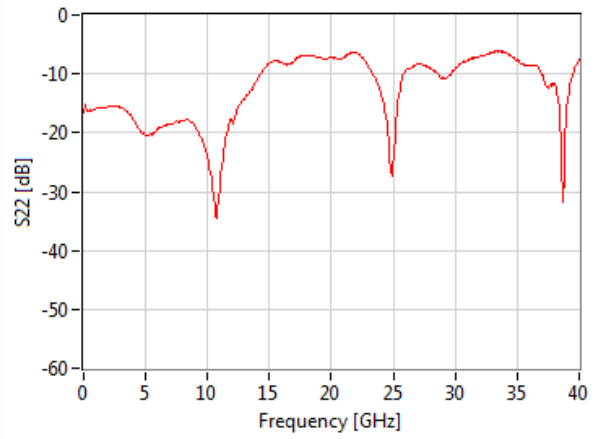
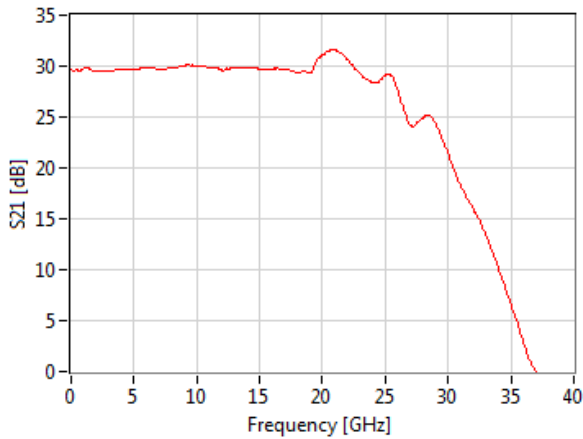
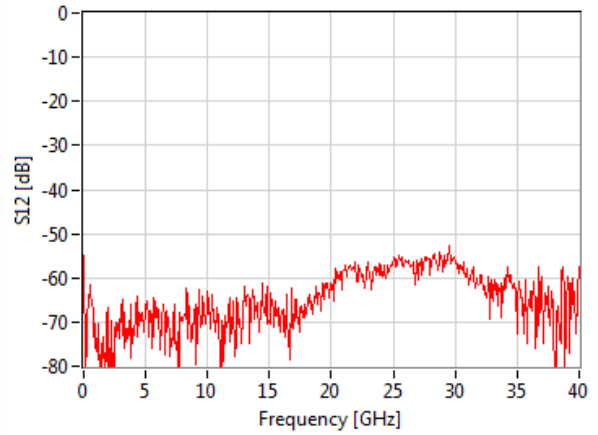
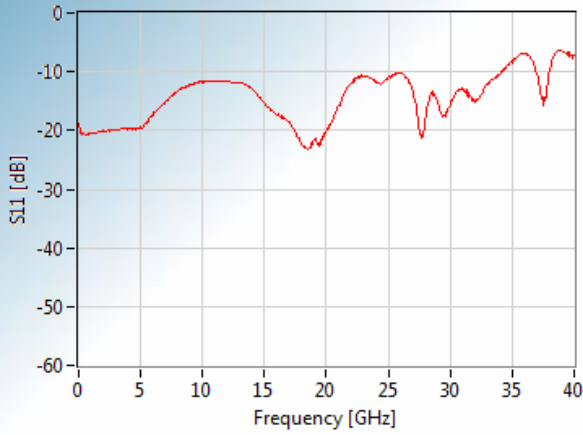

Aperture of group delay measurement: 160 MHz



Typical Noise Figure

The measurement had been performed using a FSW85 Spectrum Analyzer by Rhode & Schwarz. The noise figure defines the degradation of the signal-to-noise ratio when the signal passes the amplifier. An ideal amplifier would amplify the noise at its input along with the signal. However, a real amplifier adds some extra noise from its own components and degrades the signal-to-noise ratio. Please note that this applies to small signals only. When the amplifier is used close to or in its saturation region additional non-linear effects will impact the signal-to-noise ratio and the signal waveform.

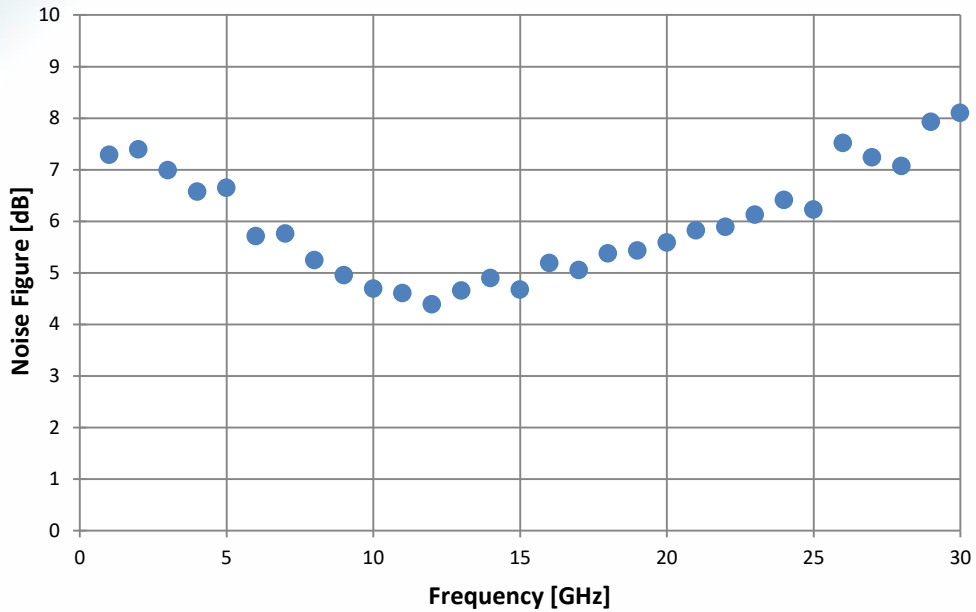



Typical Binary Waveforms

Measurements had been performed using a SHF 12103 A BPG and an Agilent 86100C DCA with Precision Time Base Module (86107A) and 70 GHz Sampling Head (86118A).

Eye Amplitude: Input ~480 mV ⇒ Output ~12 V

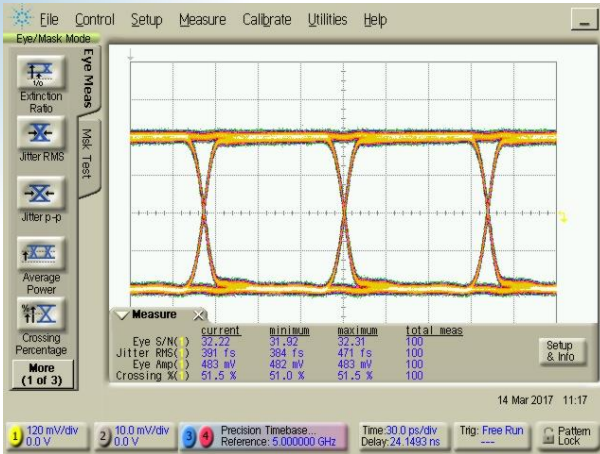

Input Signal @ 10 Gbps

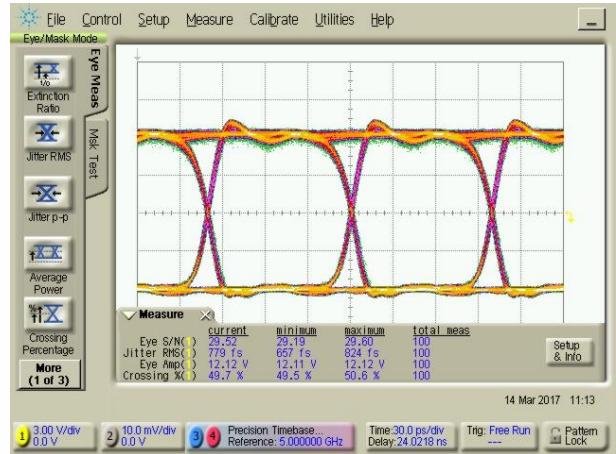

Output Signal @ 10 Gbps

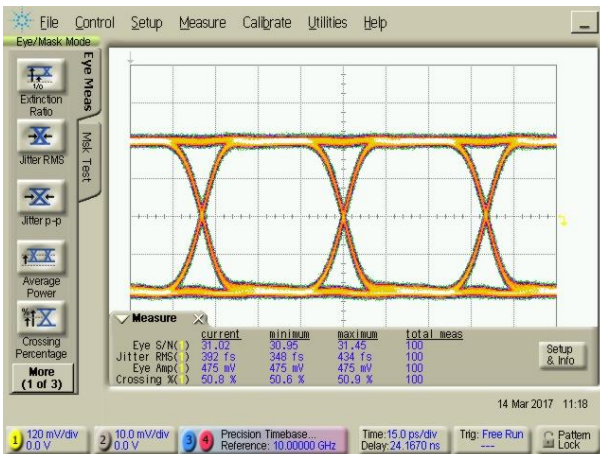

Input Signal @ 20 Gbps

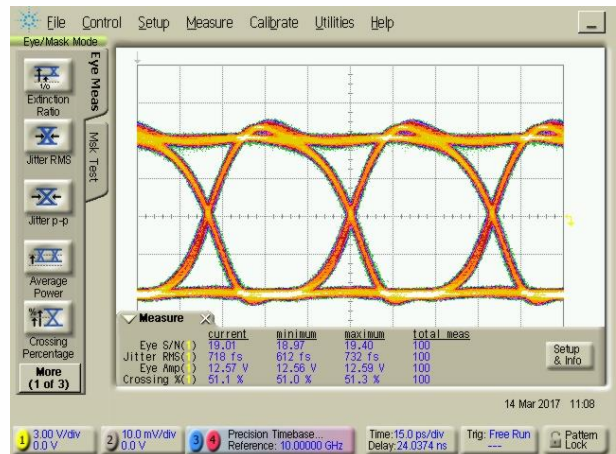

Output Signal @ 20 Gbps

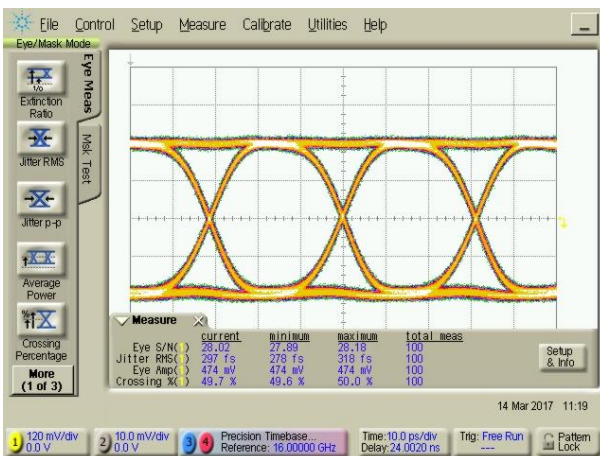

Input Signal @ 32 Gbps

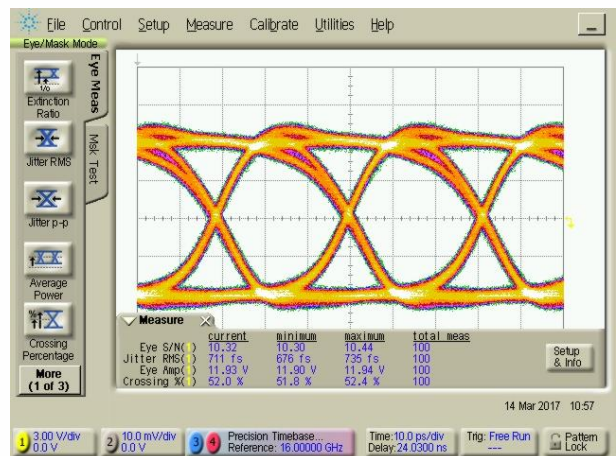

Output Signal @ 32 Gbps



Typical 4-Level Waveforms

Measurements had been performed using a SHF 611 C DAC with low pass filter 17 GHz and an Agilent 86100C DCA with Precision Time Base Module (86107A) and 70 GHz Sampling Head (86118A).

Eye Amplitude: Input ~340 mV ⇒ Output ~10 V

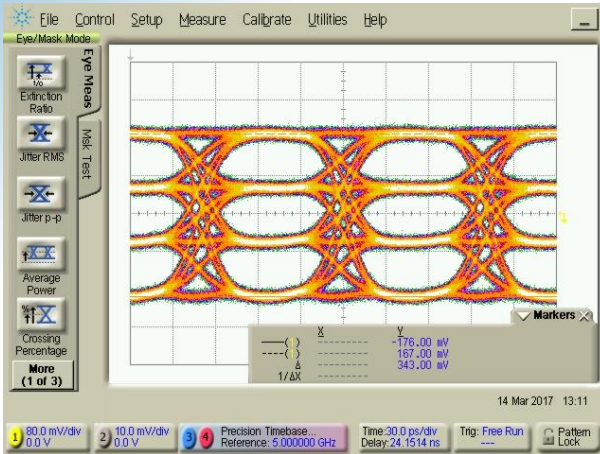

Input Signal @ 10 GBaud

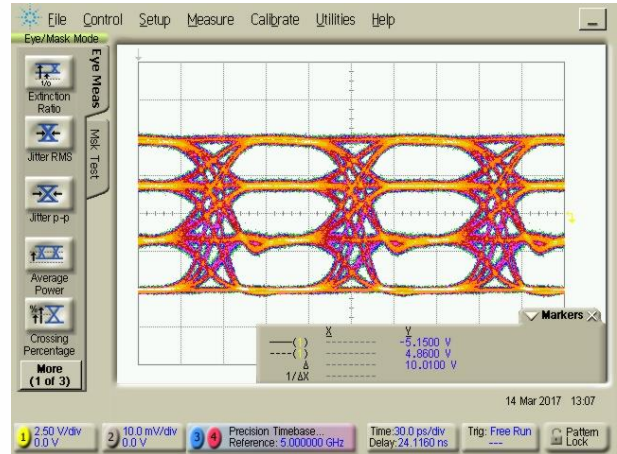

Output Signal @ 10 GBaud



Typical Low Frequency Response (<40 MHz)

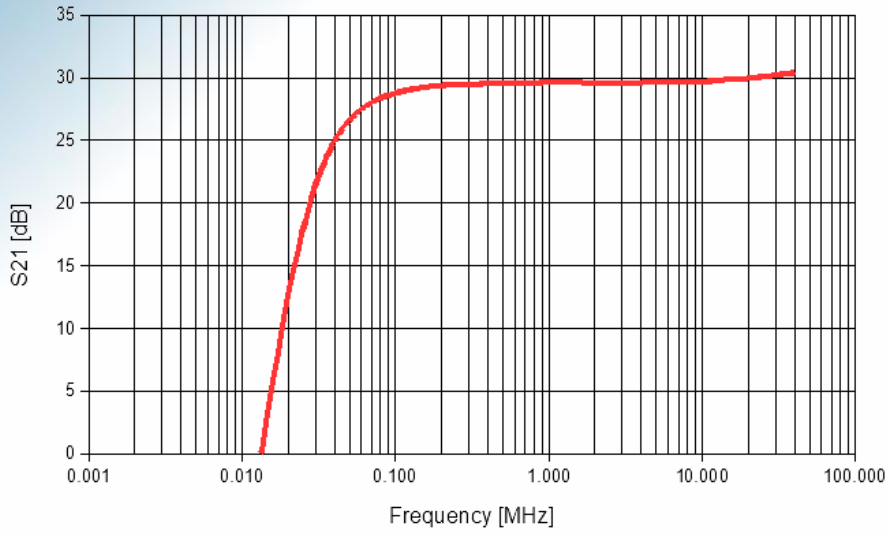

Typical Saturation power

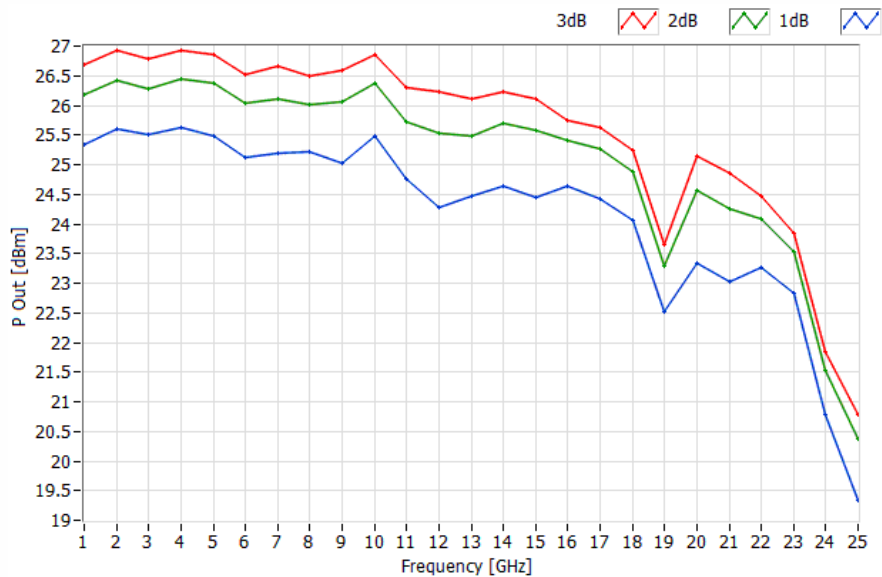

Top (red): 3 dB compression;
Middle (green): 2 dB compression;
Bottom (blue): 1 dB compression



Mechanical Drawing with Heat Sink

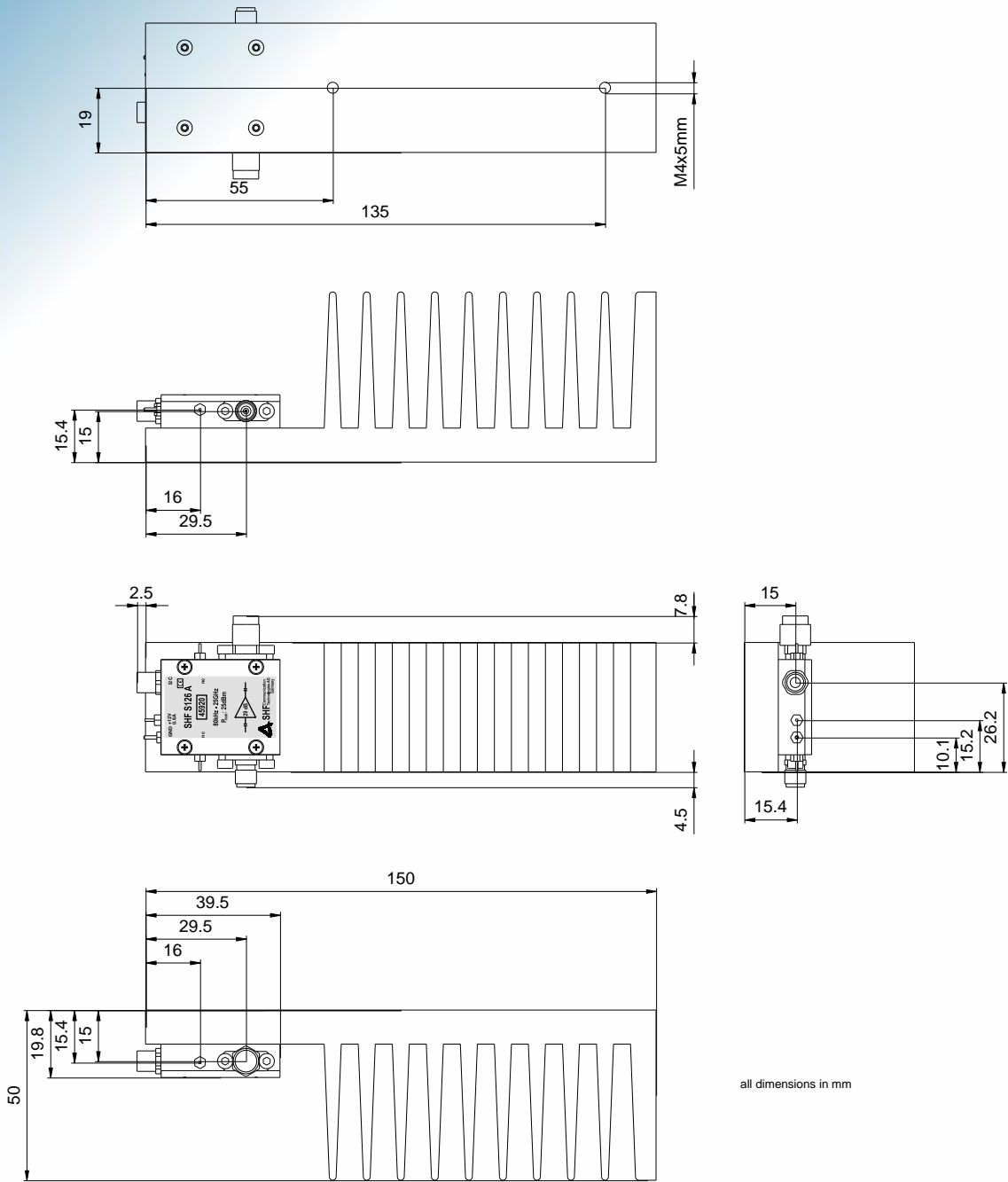

Pin assignment might change if a bias tee option is chosen.

For permanent mounting remove the heat sink from the amplifier. In that case please ensure that adequate cooling of the amplifier is guaranteed. It is recommended to use thermal paste or a thermal gap pad for the mounting. In order to separate the heat sink from the amplifier, remove the four screws on the heat sink. Please note, thermal paste is used between the heat sink and the amplifier housing.



Mechanical Drawing without Heat Sink

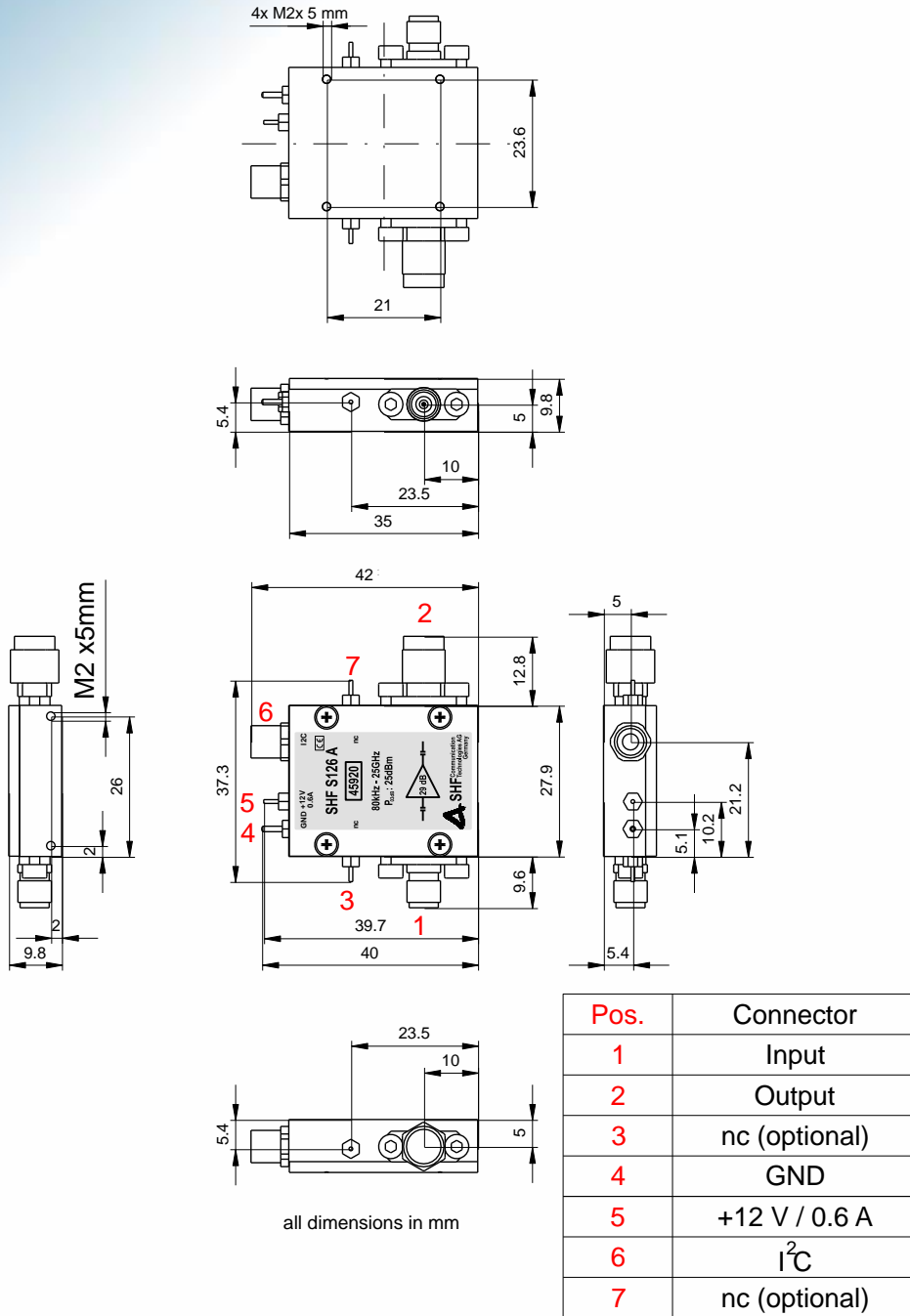

Pin assignment might change if a bias tee option is chosen.

Please ensure that adequate cooling of the amplifier is guaranteed.



User Instructions

ATTENTION!

Electrostatic sensitive GaAs FET amplifier

1. To prevent damage through static charge build up, cables should be always discharged before connecting them to the amplifier!
2. Attach a 50 Ohm output load before supplying DC power to the amplifier!
3. The supply voltage can be taken from any regular 11 ...13 V, (0.6 A @ 12 V) DC power supply and can be connected to the supply feed-through filter via an ON / OFF switch.

In case 12 V are applied to the amplifier typically 0.5 A are drawn during operation. However, the amplifier requires more current during start up. This is particularly important in case the current compliance of a very fast acting voltage source is set too tight. As this can prevent the amplifier from starting properly, please allow up to 100% overhead for your current compliance during startup.

4. Using a 3 dB or 6 dB input attenuator will result in a 6 dB or 12 dB increase of the input return loss. For minimal degradation of amplifier rise time, these attenuators should have a bandwidth specification of greater 30 GHz (K / 2.92 mm attenuators)!
5. A input signal of about 0.55 Vpp will produce output swing of about 12 Vpp. Higher input voltages are leading to waveform degradation.
6. The amplifier can only be used without damage by connecting a 50 Ohm precision load to the output.
7. ATTENTION: At radio frequencies a capacitive load can be transformed to an inductive one through transmission lines! With an output stage driven into saturation this may lead to the immediate destruction of the amplifier (within a few ps)!
8. The input voltage should never be greater than 1 Vpp equivalent to 4 dBm input power.
9. For the DC-connections flexible cable 0.2...0.5 mm² / AWG 24...20 are recommended. A maximum soldering temperature of 260 °C for 3 seconds is recommended for the feedthrough (positive supply voltage and bias tee pin). The ground pin requires significantly more heat as it is connected to the solid housing.