

MATERIAL/FINISH PROPERTIES

MATERIAL PROPERTIES:

BODY: BRASS PER ASTM B16 OR EQUIVALENT
 CENTER CONTACT: BERYLLIUM COPPER PER ASTM B196 OR EQUIVALENT
 INTERMEDIATE CONTACT: BRASS PER ASTM B16 OR EQUIVALENT
 INSULATORS: PTFE PER ASTM D1710 OR EQUIVALENT
 GASKETS: SILICONE RUBBER PER AA59588 OR EQUIVALENT

PLATING PROPERTIES:

BODY: .000100 MIN. NICKEL PER QQ-N-290
 CONTACTS: .000030 MIN. GOLD PER MIL-G-45204 OVER
 .000050 MIN. NICKEL PER QQ-N-290

MECHANICAL/ELECTRICAL PROPERTIES

CONNECTOR MEETS: MIL-STD-348 FIG. 202-2, MIL-PRF-49142
 CONNECTOR MEETS: RoHS 2002/95/EC STANDARDS
 CONNECTOR DURABILITY: 500 CYCLES MIN.
 MOUNTING: PER ES117-BK350
 PANEL THICKNESS: .125 [3.2] MAX.
 CABLE: RG403 OR EQUIVALENT
 ASSEMBLY INSTRUCTIONS: AI441
 IMPEDANCE: NON CONSTANT
 VOLTAGE RATING: 400 VRMS
 INSULATION RESISTANCE: 5,000 MEGOHMS
 DIELECTRIC WITHSTANDING VOLTAGE: 1,200 VRMS

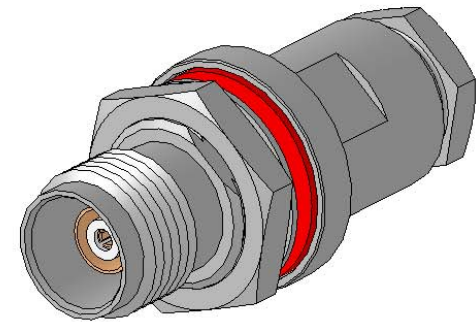
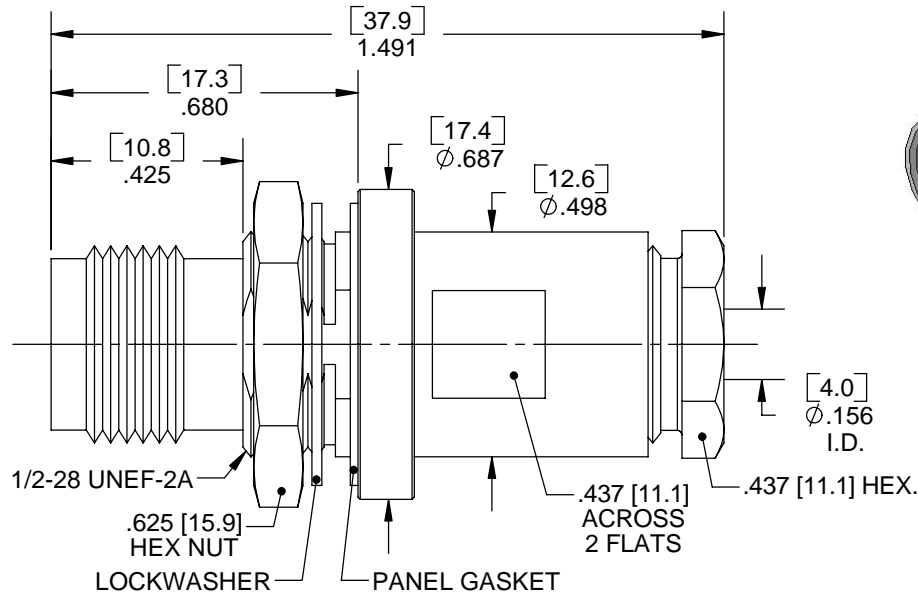

NOTES: 1. ALL ITEMS SHIP LOOSE IN BAG

IntelliConnect

UNLESS OTHERWISE SPECIFIED

ALL DIMENSIONS ARE REFERENCE
 X.XXX DIM'S = INCHES * [X.XX] DIM'S = MILLIMETERS
 SURFACE FINISH: 63 MICRO MAX.
 ALL DIAMETERS TO BE CONCENTRIC WITHIN .005 F.I.M.

TITLE: TRT STRAIGHT BULKHEAD MOUNT CABLE U/G CLAMP JACK

MATERIAL & FINISH: PER TABLE ABOVE

DRAWN BY: SRS	CHECK BY: PCS	APPR. BY: TLB
DATE: 11/21/12	DATE: 11/21/12	DATE: 11/21/12
CAGE CODE NO: 5N5S5	SCALE: 6:1	SIZE: A
SALES DRAWING	PART NO. 0133-J1BK-417-100N	SHEET 1 OF 1

A	NPR 893E	TLB	11/21/12
REV	DESCRIPTION	APPR	DATE