

MATERIAL/FINISH PROPERTIES

MATERIAL PROPERTIES:
 BODY: BRASS PER ASTM B16 OR EQUIVALENT
 CENTER CONTACT: BERYLLIUM COPPER PER ASTM B196 OR EQUIVALENT
 CABLE CONTACT: BRASS PER ASTM B16 OR EQUIVALENT
 INSULATOR: PTFE PER ASTM D1710 OR EQUIVALENT
 GASKETS: SILICONE RUBBER PER ZZ-R-765 OR EQUIVALENT

PLATING PROPERTIES:
 BODY: .000100 MIN. NICKEL PER QQ-N-290
 CONTACTS: .000030 MIN. GOLD PER MIL-G-45204 OVER
 .000050 MIN. NICKEL PER QQ-N-290

MECHANICAL/ELECTRICAL PROPERTIES

CONNECTOR MEETS: MIL-STD-348, MIL-PRF-39012
 CONNECTOR MEETS: RoHS 2002/95/EC STANDARDS
 CONNECTOR DURABILITY: 500 CYCLES MIN.
 CABLE: RG316 OR EQUIVALENT
 ASSEMBLY INSTRUCTIONS: AI240
 IMPEDANCE: 50 OHMS NOMINAL
 FREQUENCY RANGE: DC-11 GHz
 VOLTAGE RATING: 500 VRMS
 INSULATION RESISTANCE: 5,000 MEGOHMS
 DIELECTRIC WITHSTANDING VOLTAGE: 1,500 VRMS

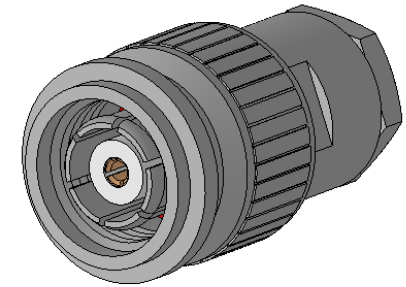
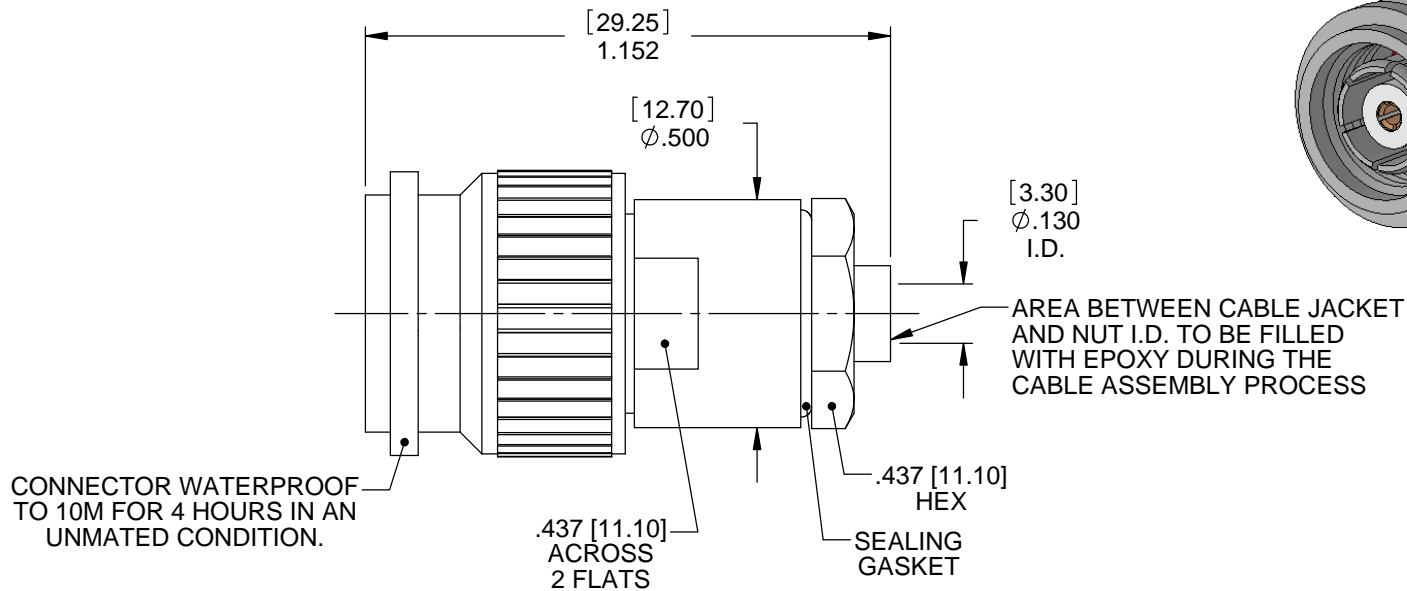

IntelliConnect

UNLESS OTHERWISE SPECIFIED
 ALL DIMENSIONS ARE REFERENCE
 X.XXX DIM'S = INCHES * [X.XX] DIM'S = MILLIMETERS
 SURFACE FINISH: 63 MICRO MAX.
 ALL DIAMETERS TO BE CONCENTRIC WITHIN .005 F.I.M.

TITLE: TNC REVERSE POLARITY SEALED STRAIGHT
CABLE WEDGE CLAMP PLUG

MATERIAL & FINISH: PER TABLE ABOVE

DRAWN BY: SRS	CHECK BY: PCS	APPR. BY: TLB
DATE: 08/16/07	DATE: 08/16/07	DATE: 08/16/07

CAGE CODE NO: 5N5S5	SCALE: 2.5:1	SIZE: A	REV: D
----------------------------	---------------------	----------------	---------------

SALES DRAWING	PART NO. 5124-Z1NN-201-101N	SHEET 1 OF 1
----------------------	---------------------------------------	------------------------

D	ECN 1420	TLB	11/05/13
C	ECN 1344	TLB	01/16/12
B	ECN 1339	TLB	12/20/11
A	NPR 482	TLB	08/16/07
REV	DESCRIPTION	APPR	DATE