

**MATERIAL/FINISH PROPERTIES**

**MATERIAL PROPERTIES:**

BODY: STAINLESS STEEL PER ASTM A582 OR EQUIVALENT  
 CONTACT: BERYLLIUM COPPER PER ASTM B196 OR EQUIVALENT  
 INSULATORS: PTFE PER ASTM D1710 OR EQUIVALENT  
 GASKET: SILICONE RUBBER PER ZZ-R-765 OR EQUIVALENT

**PLATING PROPERTIES:**

BODY: PASSIVATE PER QQ-P-35, TYPE II  
 CONTACT: .000030 MIN. GOLD PER MIL-G-45204 OVER  
 .000050 MIN. NICKEL PER QQ-N-290

**MECHANICAL/ELECTRICAL PROPERTIES**

CONNECTOR MEETS: MIL-STD-348, MIL-PRF-39012  
 CONNECTOR MEETS: RoHS 2002/95/EC STANDARDS  
 CONNECTOR DURABILITY: 500 CYCLES MIN.  
 MOUNTING: PER ES117-BK350  
 PANEL THICKNESS: .125 [3.2] MAX.  
 IMPEDANCE: 50 OHMS NOMINAL  
 FREQUENCY RANGE: DC-4 GHZ  
 VOLTAGE RATING: 335 VRMS  
 INSULATION RESISTANCE: 5,000 MEGOHMS  
 DIELECTRIC WITHSTANDING VOLTAGE: 1,500 VRMS

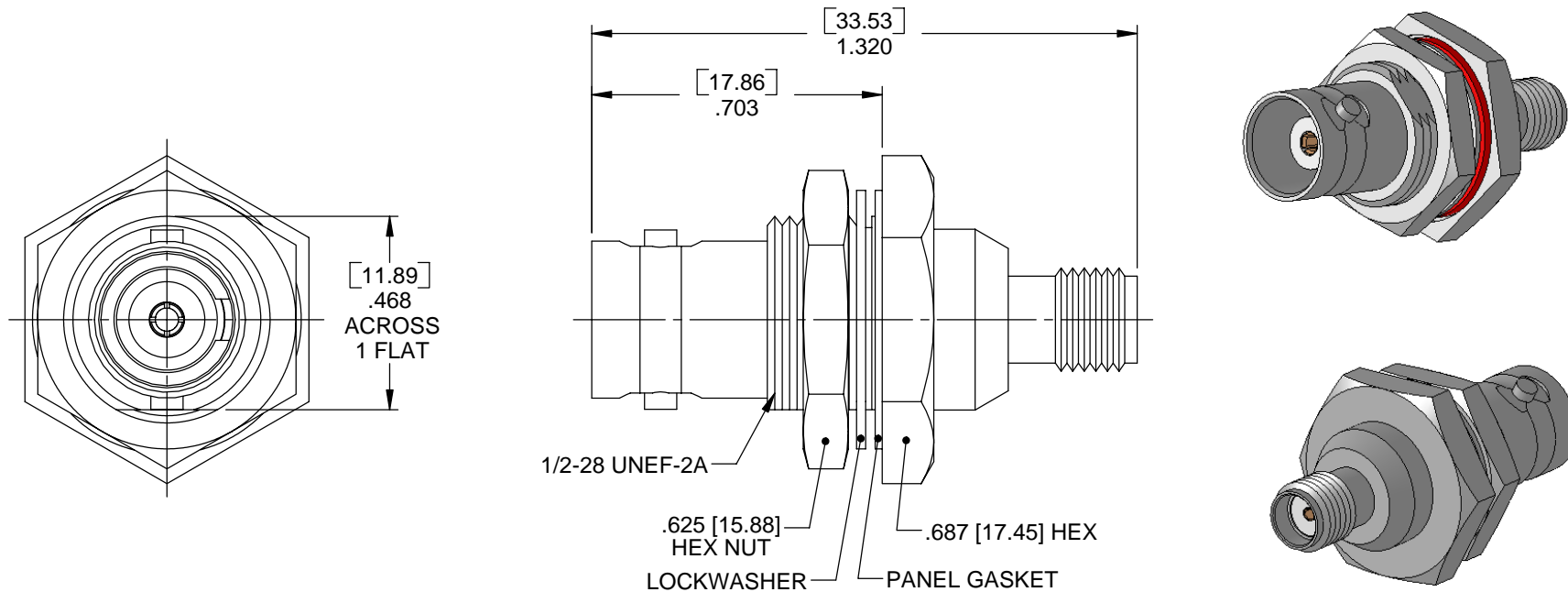

**IntelliConnect**

**UNLESS OTHERWISE SPECIFIED**

ALL DIMENSIONS ARE REFERENCE  
 X.XXX DIM'S = INCHES \* [X.XX] DIM'S = MILLIMETERS  
 SURFACE FINISH: 63 MICRO MAX.  
 ALL DIAMETERS TO BE CONCENTRIC WITHIN .005 F.I.M.

**TITLE:** BNC JACK TO SMA JACK BULKHEAD ADAPTER

**MATERIAL & FINISH:** PER TABLE ABOVE

<b>DRAWN BY:</b> SRS	<b>CHECK BY:</b> PCS	<b>APPR. BY:</b> TLB
<b>DATE:</b> 09/18/06	<b>DATE:</b> 09/18/06	<b>DATE:</b> 09/18/06

<b>CAGE CODE NO:</b> 5N5S5	<b>SCALE:</b> 2.5:1	<b>SIZE:</b> A	<b>REV:</b> A
----------------------------	---------------------	----------------	---------------

<b>SALES DRAWING</b>	<b>PART NO.</b> A5707-1BK-100P	<b>SHEET</b> 1 OF 1
----------------------	-----------------------------------	------------------------

A	NPR 425	TLB	06/15/07
<b>REV</b>	<b>DESCRIPTION</b>	<b>APPR</b>	<b>DATE</b>