

Low Noise Amplifier

Ka band

21-31 GHz



Product Datasheet

LNA11202131SS

Multi-stage modular low noise amplifier.

Overview

The LNA11202131SS is a multi-stage modular low noise amplifier that covers frequencies from 21 GHz to 31 GHz*. The LNA provides up to 34 dB gain with a noise figure of 2.5 dB from a single supply voltage from 7 V to 40 V. The LNA incorporates an enable/disable, current and temperature sensor function allowing for remote fault analysis.

The LNA is fully enclosed in a housing with 2.92 RF connections and D-Sub for DC power, enable, current and temperature sensor connection.



*Operates from 17 GHz with reduced gain



Features

- 21-31 GHz frequency range*
- 34 dB gain
- 2.5 dB noise figure
- Unconditionally stable
- No negative DC supply requirement



Applications

- High speed data communications
- Space communications
- IOT
- Security
- 5G

Low Noise Amplifier

Ka band

21-31 GHz



Product Datasheet

Specification Overview

Parameter	Min	Typ	Max	Units
Frequency	21		31	GHz
Gain	30	32	34	dB
Input Return Loss	5	15		dB
Output Return Loss	7	12		dB
Noise Figure		2.5	2.8	dB
Voltage	7		40	V

Notes

All tests are carried out at 25°C

Tests have been performed with 100 pF de-coupling capacitors on all bias pads.

Absolute Maximum Ratings

Parameter	Rating
Drain Voltage	40 V
Drain Current	200 mA
RF Input Power	7 dBm
Storage Temperature	-65 °C to +150 °C
Operating Temperature	-40 °C to +85 °C



ESD (electrostatic discharge) sensitive device. Charged devices and circuit boards can discharge without detection. Although this product features proprietary protection circuitry, damage may occur on devices subjected to ESD. Proper ESD precautions should be taken to avoid performance degradation or loss of functionality.

Low Noise Amplifier

Ka band

21-31 GHz



Product Datasheet

Measured Performance Data

Noise Figure

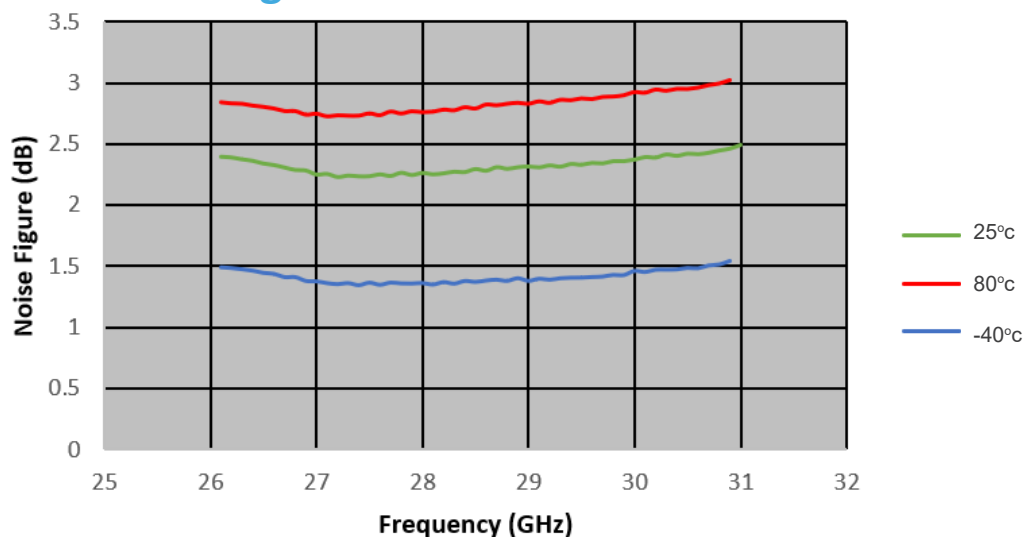

Return Loss

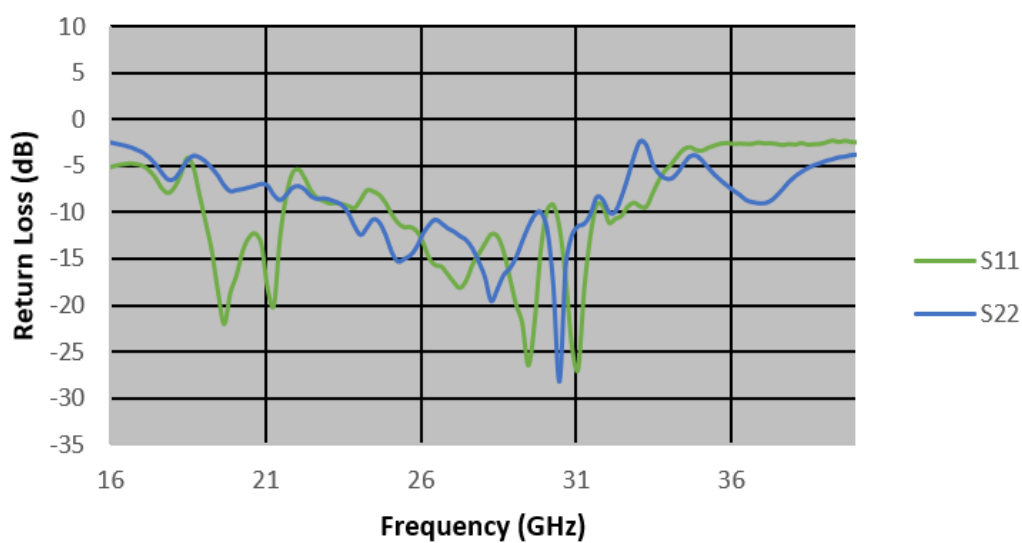

Low Noise Amplifier

Ka band

21-31 GHz



Product Datasheet

Measured Performance Data

S21

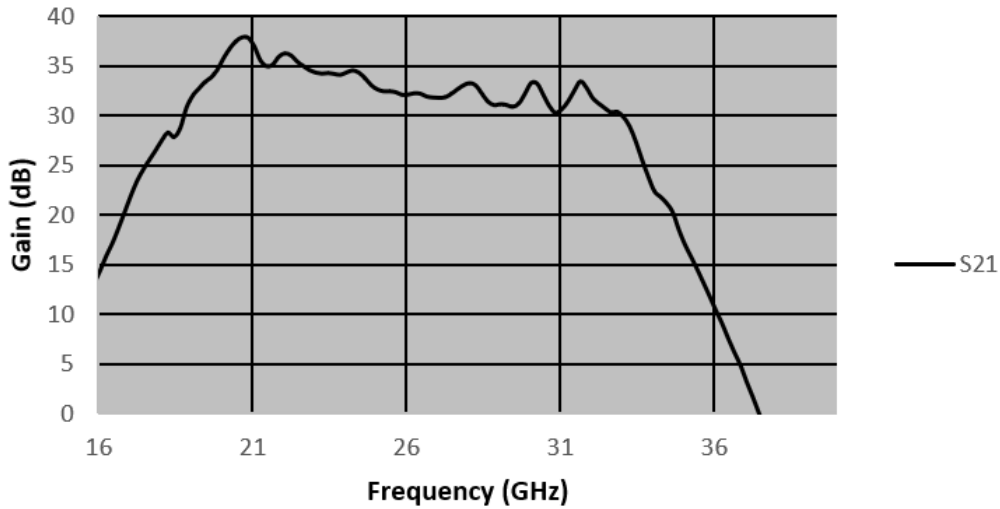

Gain VS Output Power

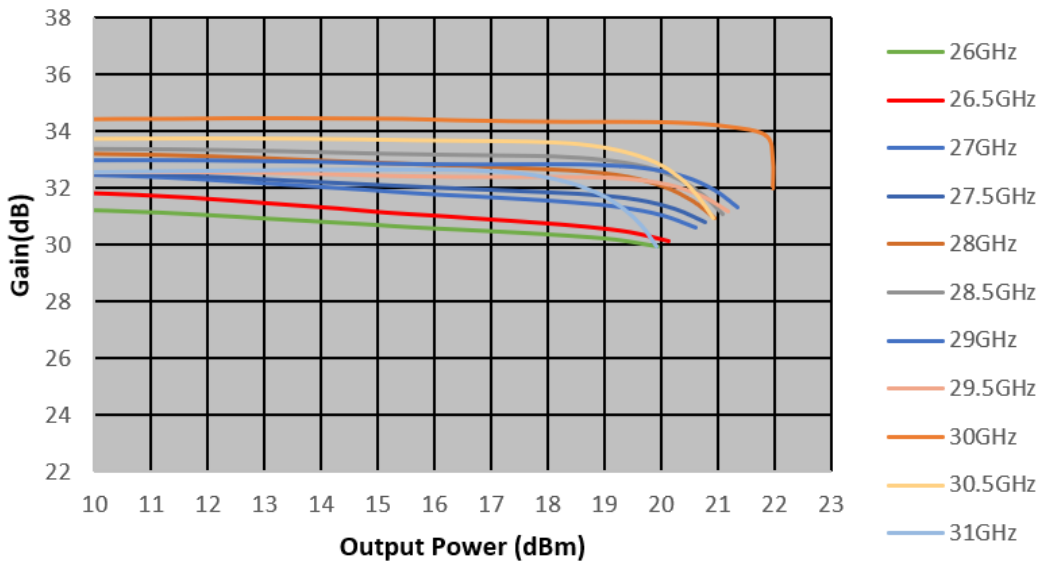

Low Noise Amplifier

Ka band

21-31 GHz



Product Datasheet

Outline Drawings

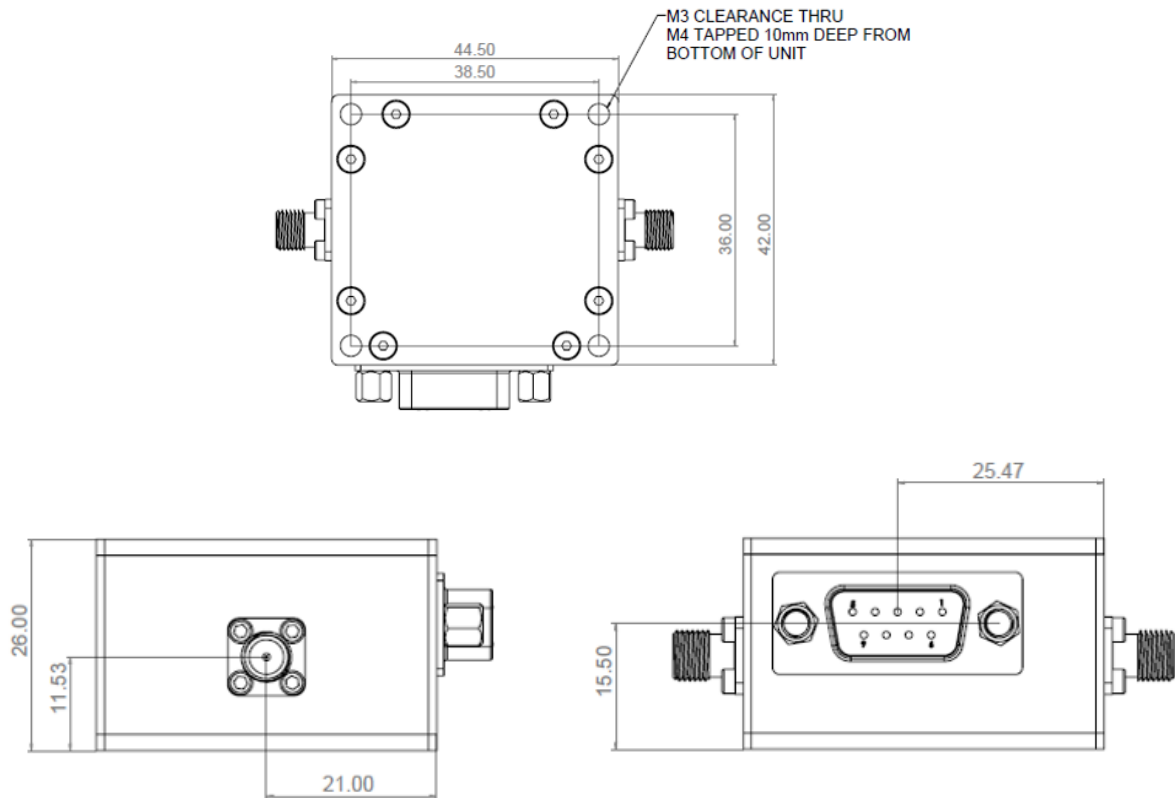

Connection Configurations

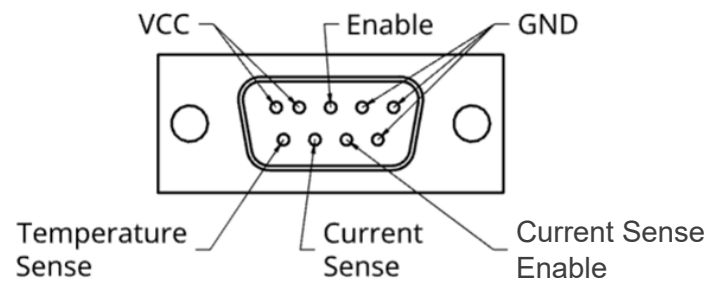

ReliaSat European Offices

sales@reliasat.com

www.reliasat.com